

**ATL 2 ABREAST FEEDERS**  
**INSTALLATION**  
**and**  
**OPERATING INSTRUCTIONS**

A.T.L. AGRICULTURAL TECHNOLOGY LTD  
THE PARLOUR FEEDING SPECIALISTS

Place Farm, Kirtling  
Newmarket, Suffolk  
England. CB8 9PA

Tel: (01638) 731212  
Fax: (01638) 731174

# ATL 2 ABREAST FEEDERS

## Installation Instructions

Issue 2ABDMC 1:01  
Abreast + Micro Control

## INSTALLATION

### GENERAL NOTES

All Installation & Operating Instructions and Notes should be read thoroughly and understood before commencing installation or any remedial work.

IF IN DOUBT - ASK.

All electrical wiring should be conduited where necessary and be in accordance with current codes of practice.

Any notes or recommendations in these instructions and notes that are not observed may invalidate any warranty claim.

All conduited wiring connections to any of the control boxes or Power Supply Unit should be waterproofed by using a suitable solvent welding solution and sealants where necessary. All entry points into the Controls should be into the base of the boxes, if entry points on the sides are unavoidable, the cable & conduit should be looped downwards to shed water before reaching entry point. Entry through top of the box must be avoided at all costs.

If any rubber switch seal becomes split, cut or damaged, it must be replaced immediately. Any ingress of water can seriously harm the switch and components in the boxes. No warranty claims can be considered under these conditions.

### THE ATL ABREAST FEEDERS (Without Manger Unit)

The Abreast Feeders have been specifically designed for the easy updating of existing manual & shovel feed type Abreast stalls as well as for new Abreast parlours using tubular stall work by others. The two way flap valve directs the feed into the manger selected - this can be either for manual or automatic control.

The Feeder is a very compact unit and consists of an auger driven by a low voltage DC supply electric geared motor unit which dispenses feed on a volumetric basis. The rate of feed can be adjusted by means of a calibration control slide mounted on the top of the Feeder. This is generally used only for initial setting up to equalise all the Feeders, since final calibration is undertaken from the Control system - when all Feeders are calibrated at the same time.

The Feeder is normally positioned on the flat feeding tray, centrally in the stall. The base of the existing hopper (holding bin) should be cut back just to allow the Feeder to

slide under the hopper and rest against the back plate. The back of the Feeder and the hopper back plate should then be drilled and riveted firmly together.

The flat feeding tray and manger division plate should be cut back to allow the Feeder outlet to be sited correctly and to be held firmly in position. Use an additional small angle to fix securely if required.

The two sets of HOPPER INFIL PANELS (if required) are each supplied in three sections for riveting together on site (see sketch) to suit not only the width of the existing hopper but the angle of the hopper front. These composite panels should then be riveted into the existing hopper so that the concentrates or feed are funnelled into the Feeder without leaving any 'dead' areas.

Care should be taken in respect of the final angles of the hopper infill panels and the existing front panel - in that the angles should be suitable to allow free flow of the feed without lodging. Sometimes further work may be necessary on site to ensure that the correct angles are maintained.

If the hopper opening is so wide that the calibration slide is either fouled or inside the hopper, then the Feeder should be pulled forward so that the slide is clear and an additional baffle plate will be required to infill between the back of the Feeder and the rear of the hopper so that no 'dead' areas are left. This baffle plate should be securely fixed so that the Feeder is held rigidly in position. Alternatively, and very often the easiest solution, is to position the Feeder against the hopper back plate and release the fixings at the bottom of the existing hopper front panel so that it can be bent back so that it rests behind the calibration slide - the panel can then be re-fixed in this position. See note above regarding correct angles in the hopper.

The electrical supply cable passes into the motor compartment of the Feeder by means of a grommet on the back of the motor compartment. The positive (+) DC supply wire is connected to the red wired terminal connection (the positive line is switched) and the negative (-) wire to the other terminal connection - see sketch and later notes regarding cable size etc.

### THE ATL ABREAST FEEDERS (With Manger Unit)

The Feeder and Manger Unit with Division, Front and Back plate is supplied as one unit and the Feeder is supported on the Manger Unit. The existing manger should be cut out underneath the existing hopper and the new unit installed in its place.

The hopper infill panels and work to the existing hopper (holding bin) should be as generally described above.

# ATL 2 ABREAST FEEDERS

## Installation Instructions

The Manger Units are supplied with the outer sides loose to be riveted together on site to suit the width of the stall work. The angle flanges for the mangers (supplied loose) should be fitted on site to suit the height and position of the stall work supporting the mangers and securely fixed to the mangers and stall work. The angle flange should be dressed over the support rail to provide a neat smooth edge to the manger. If the height of the existing support rail necessitates the angle flange being fitted below the top edge of the manger, then a further strip of galvanised steel should be dressed over the top edge of the manger. The back plate of the Manger Unit should be fixed to the bottom of the hopper unit and the sides of the manger back plate should be strapped to the existing upright stall work.

If the existing manger was longer than the new unit, it may be necessary to insert a protection rail to stop the cows head from getting into the centre of the stall and knocking the flap control gear of the Feeder.

### **HOLDING BIN or HOPPER (if supplied)**

The Holding Bin or New Hopper assembly consists of four sections, two side panels with wide flanges and front and rear panels which overlap with the side sections. The back panel overlaps with the top of the back panel of the Manger Unit and should be securely fixed together. All panels should be drilled on site to suit the stall width and firmly riveted together. The Holding Bin may need to have additional fixings back to the stall work. NOTE - Before the back panel is fixed into position - install the hopper infill panels as previously described.

### **AUTOMATIC FLAP CONTROL (if fitted)**

Two extra terminals are provided in the motor compartment for the positive supply to the Left and Right hand solenoids. As with the Feeder motor, the positive supply is switched, the negative supply to the solenoids and the motor being 'common'. These should be connected to the terminals in the Feed Controller - see later under Feed Controller. Cable should be a minimum of 1 sq mm c.s.a.

During normal use the 5 Amp overload in the Feed Controller should not trip. If the motor stalls, there will be short delay before the overload trips and the motor is disconnected. This will be indicated by the LED indicator going out. The overload will reset automatically after a short time.

### **IMPORTANT NOTE:**

*Abreast Stall work and Abreast parlours can vary very widely. We have attempted to design the ATL Abreast Feeder to suit as many different stalls and situations as possible. However, there may be situations where it is necessary to make on site alterations to ensure the correct operation and that the installation will provide a long and trouble free life.*

*For example, the Feeder is normally positioned so that the base of the auger trough is about level with the top protective bar across the top the access to the manger.*

*If the feeder is positioned at a point lower in the stall than normal so that the Feeder can easily be knocked or the two-way flap handle can be reached by the cows - then preventative measures must be taken. The addition of angles, plates or bars fixed to the stall work across the manger opening could be provided to give protection to the Feeders. The Feeder should also be supported securely at its front & rear so that the whole structure is rigid.*

*The Feeder is designed to dispense concentrates up to 3/8in, diam. (not 1/2in nuts) & home mixes with a granular content such as rolled barley or pellets and free flowing.*

*Care should be taken with the use of sugar beet pellets, fat sprayed cake or materials with a high fat content in that, depending on moisture content & condition, sticky deposits can be left in the feeders - which can eventually cause an obstruction. Regular checking should be a standard procedure - the ease of access into the feeder greatly facilitates this.*

*Care should be taken in the parlour with the use of water hoses and pressure washers. Water in the feeders can create areas of solid cake and consequential jamming. The controllers & the power supply unit, whilst giving a high degree of protection, are not designed to have water sprayed over them.*

### **Operating Instructions**

See separate Micro Control Operating instructions

## ATL Abreast Feeder with variable hopper panels in a typical shovel feed type Abreast Stall.

NOTE: The same infil panel layout generally applies (except for narrow stalls) when 2 Feeders are installed side by side.

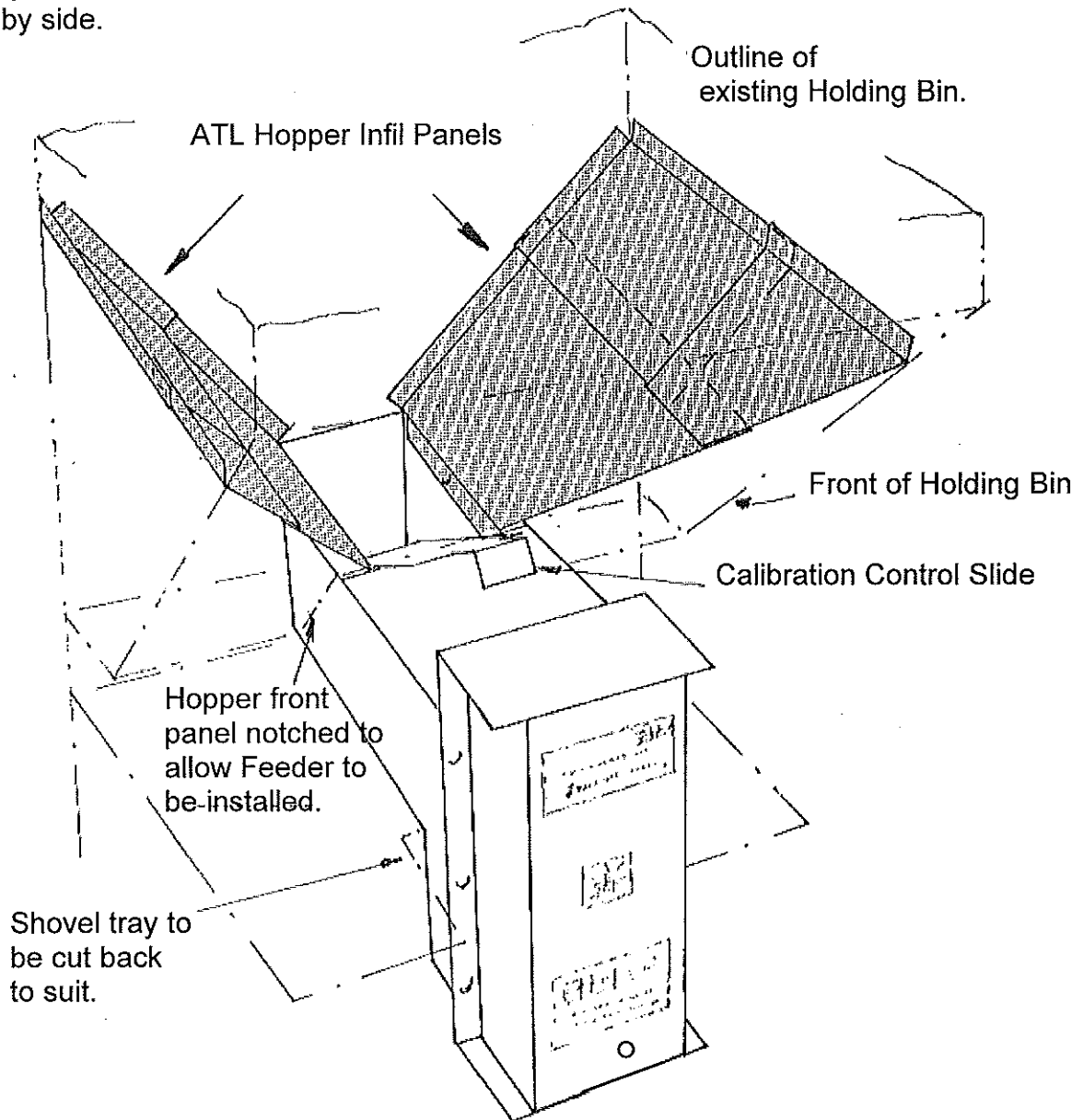

NOTE: Hopper infil panels to be riveted together and to the sides and end of holding bin with 4mm rivets.

Existing stall width and type to be notified at time of ordering.

# ATL ABREAST STALL DOUBLE FEEDER

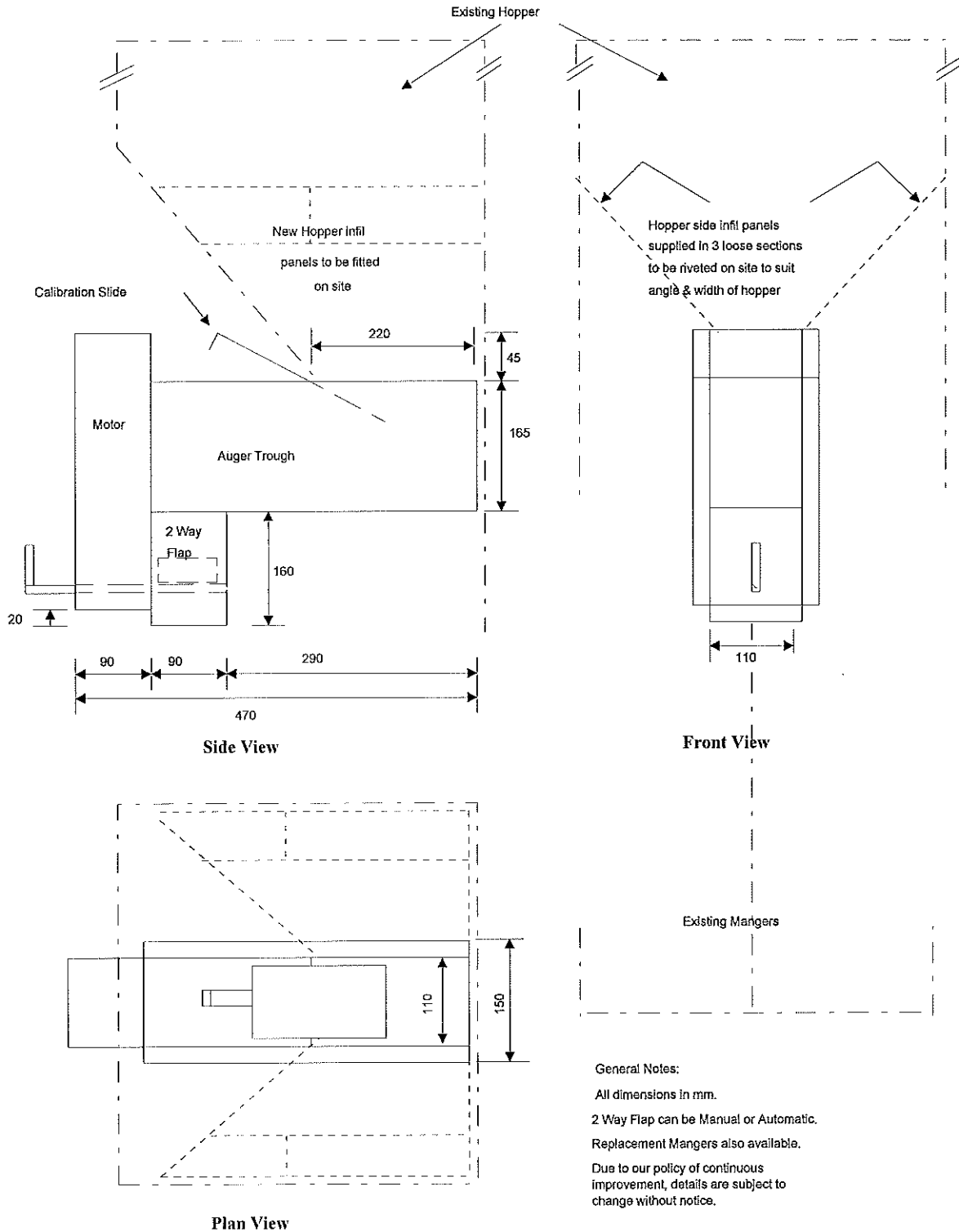

General Notes:  
 All dimensions in mm.  
 2 Way Flap can be Manual or Automatic.  
 Replacement Mangers also available.  
 Due to our policy of continuous improvement, details are subject to change without notice.

abreast 12/91

The same layout generally applies when two Feeders are fitted side by side.

## ATL ABREAST STALL DOUBLE FEEDER with ATL MANGER & HOLDING BIN

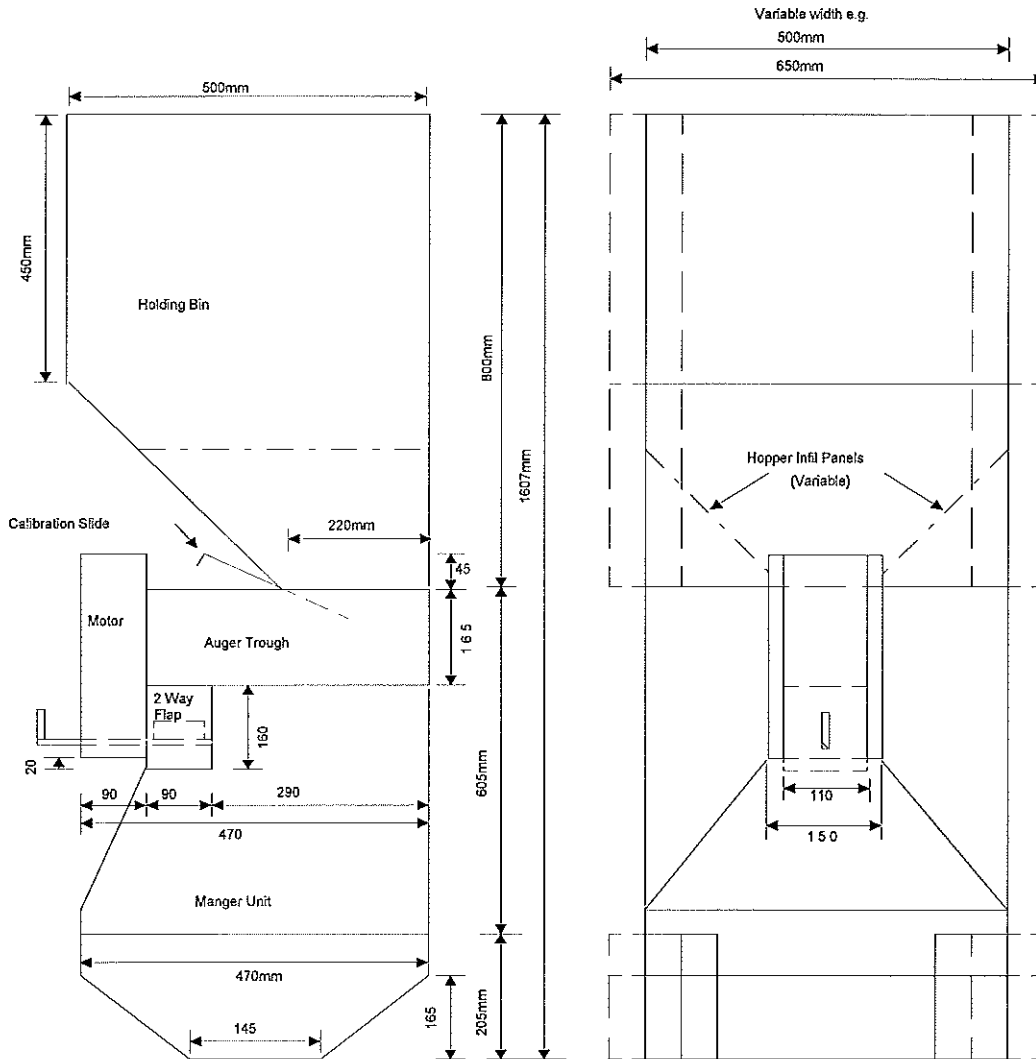

Side View

Front View

Size	Minimum Width	Maximum Width
X	450mm 1'-5 3/4"	500mm 1'-7 1/2"
A	500mm 1'-7 1/2"	650mm 2'-1 1/2"
B	650mm 2'-1 1/2"	750mm 2'-5 1/2"
C	750mm 2'-5 1/2"	850mm 2'-9 1/2"
D	850mm 2'-9 1/2"	1055mm 3'-5"

**General Notes:**

All dimensions in mm.  
 2 Way Flap can be Manual or Automatic.  
 Manger back plate width same as minimum width dimension.  
 Due to our policy of continuous improvement, details are subject to change without notice.

The same layout generally applies when two Feeders are fitted side by side.

# DATA SHEET: 42

## ABREAST FEEDER

### DIMENSIONS

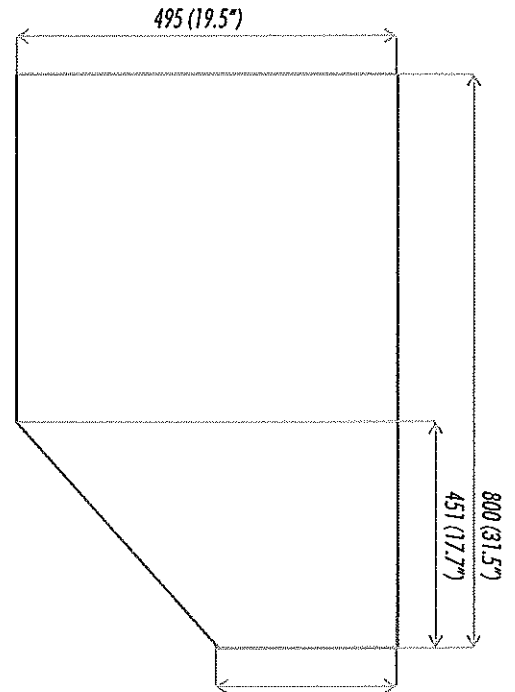
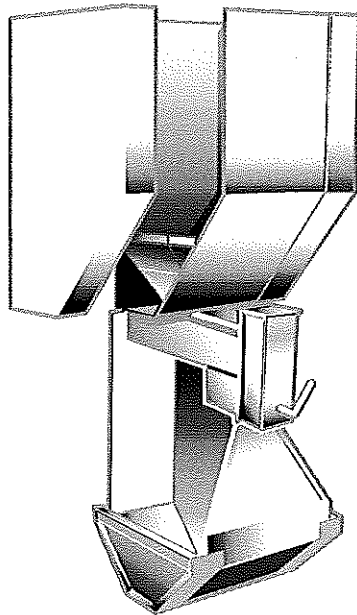

Widths: Between uprights (mm)

- 500-650 (19.7-25.5")
- 650-750 (25.5-29.5")
- 750-850 (29.5-33.5")
- 850-1100 (33.5-43.3")

