



**Innovation In and
Out of Parlour**

ACR Control Manual

Version - 1.2

Date - March 2014



Index

Manual Version.....	3
About the ACR Control.....	4
Installing the ACR Sensor.....	5
Installing the ACR Control Unit.....	5
ACR Control Wiring Connections.....	6
Switch Mode Power Supply Wiring Connections.....	7
System Wiring Overview - Standard ACR Ram.....	8
System Wiring Overview - Auto-Start ACR Ram.....	9
Accessing the Settings.....	10
The ACR Function.....	10
The ACR Hold Off Delay Setting.....	10
The Kick Off Delay Setting.....	11
The ACR Pull Off Resistance Setting.....	11
The ACR Pull Off Timer Setting.....	12
The Conductivity Function.....	12
The Conductivity Warning Level Setting.....	13
The Conductivity Pull Off Level Setting.....	13
The Vacuum Delay Setting.....	14
The Purge Setting.....	14
The Purge Hold Off Setting.....	15
The ACR Idle Time Setting.....	15
The ACR Wash Time Setting.....	16
The Start Input Is Edge Setting.....	16
Using the ACR Control.....	18
The Milking Procedure.....	18
Conductivity Level Indicators and Pull Off.....	18
Information about Milk Conductivity Measurement.....	19
The Washing Procedure.....	19
Monthly Routine Maintenance.....	20
Six Monthly Routine Maintenance.....	20
Yearly Routine Maintenance.....	20
Parlour Wash Down.....	20
Additional Items Required to Install ACR System.....	21



Manual Versions

- Version 1.0 - September 2012.....First Version of Manual (Software v1.04)
- Version 1.1 - December 2013.....Added SIE Setting and Control Valve Wiring (Software v1.08)
- Version 1.2 - March 2014.....Altered Way Control Enters and Exits Wash Mode (Software v1.10)

About the ACR Control

The ACR Control is one of the most useful additions to a milking parlour, allowing the operator to save time when milking. The ATL ACR control comes with the added extra of monitoring the conductivity of the milk. A flashing warning is displayed if the milk's conductivity is above a user selectable warning level, or pull off if the conductivity is above a user selectable pull off level. This extra function allows for advanced monitoring of your animals health, in a simple easy to use unit.

Features

- Simple numeric display of the milks conductivity;
- Colour bar graph display to indicate low to high conductivity at a glance;
- 1 Normal milking mode (ACR and conductivity enabled);
- 3 Manual milking modes (ACR disabled, Conductivity pull off disabled, ACR and conductivity pull off disabled);
- Automatic idle after a user selectable period of inactivity;
- User programable wash time;
- User selectable conductivity warning and pull off levels;
- User selectable ACR pull off resistance and time;
- Simple bright display and warning lights;
- Clever non-mechanical key pad, increases life of the unit;
- Small form factor, allowing for easy installation into existing parlours.

Front Cover

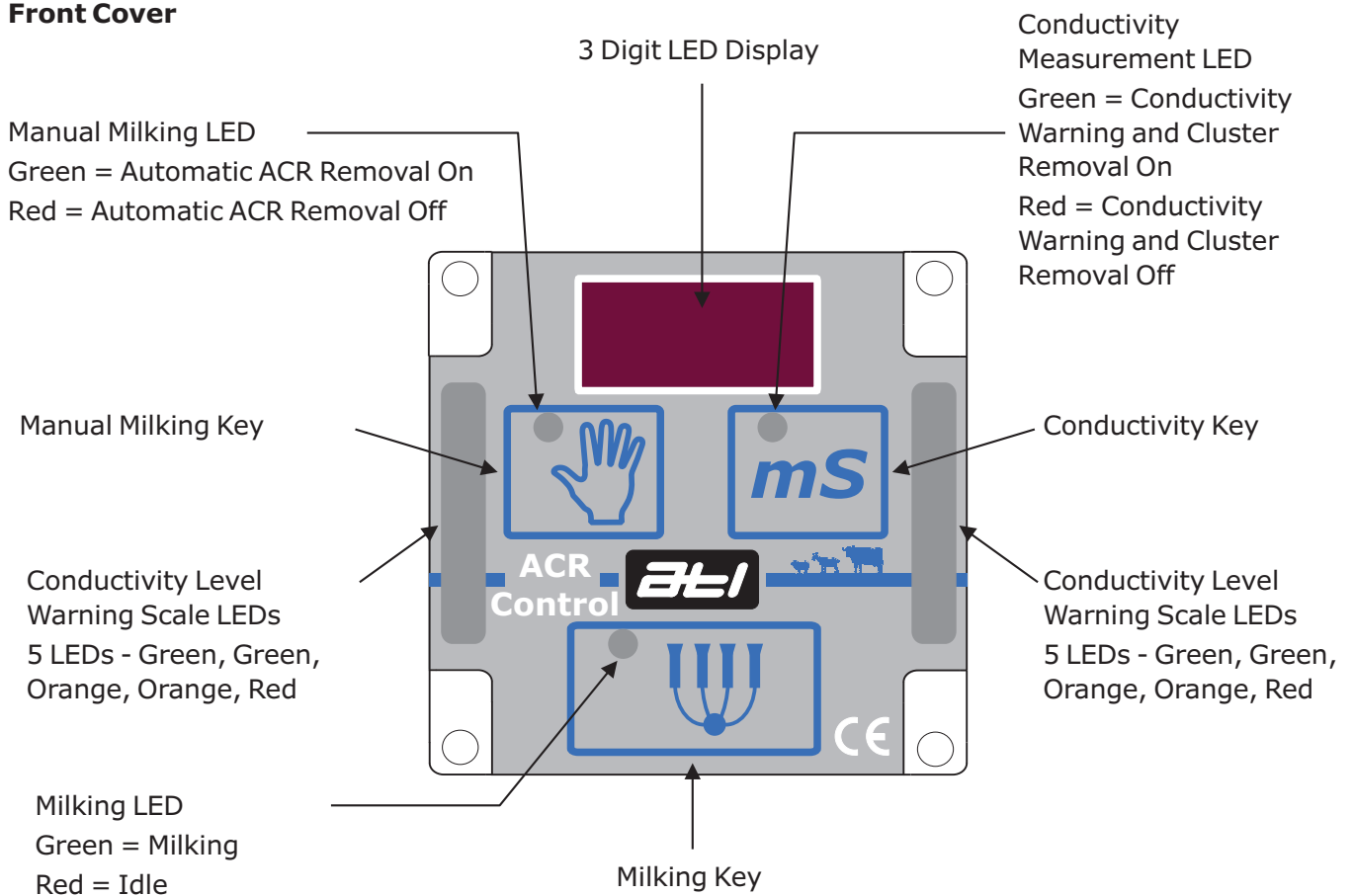

Installing the ACR Sensor



The ACR sensor should be installed so that it is aligned correctly. The vertical alignment should match the picture shown above. If the sensor is not installed in this alignment, it will not function correctly.

Installing the ACR Control

The bracket can attach to either vertical or horizontal tubes. They are supplied with 2 off 45mm u-bolts as standard.

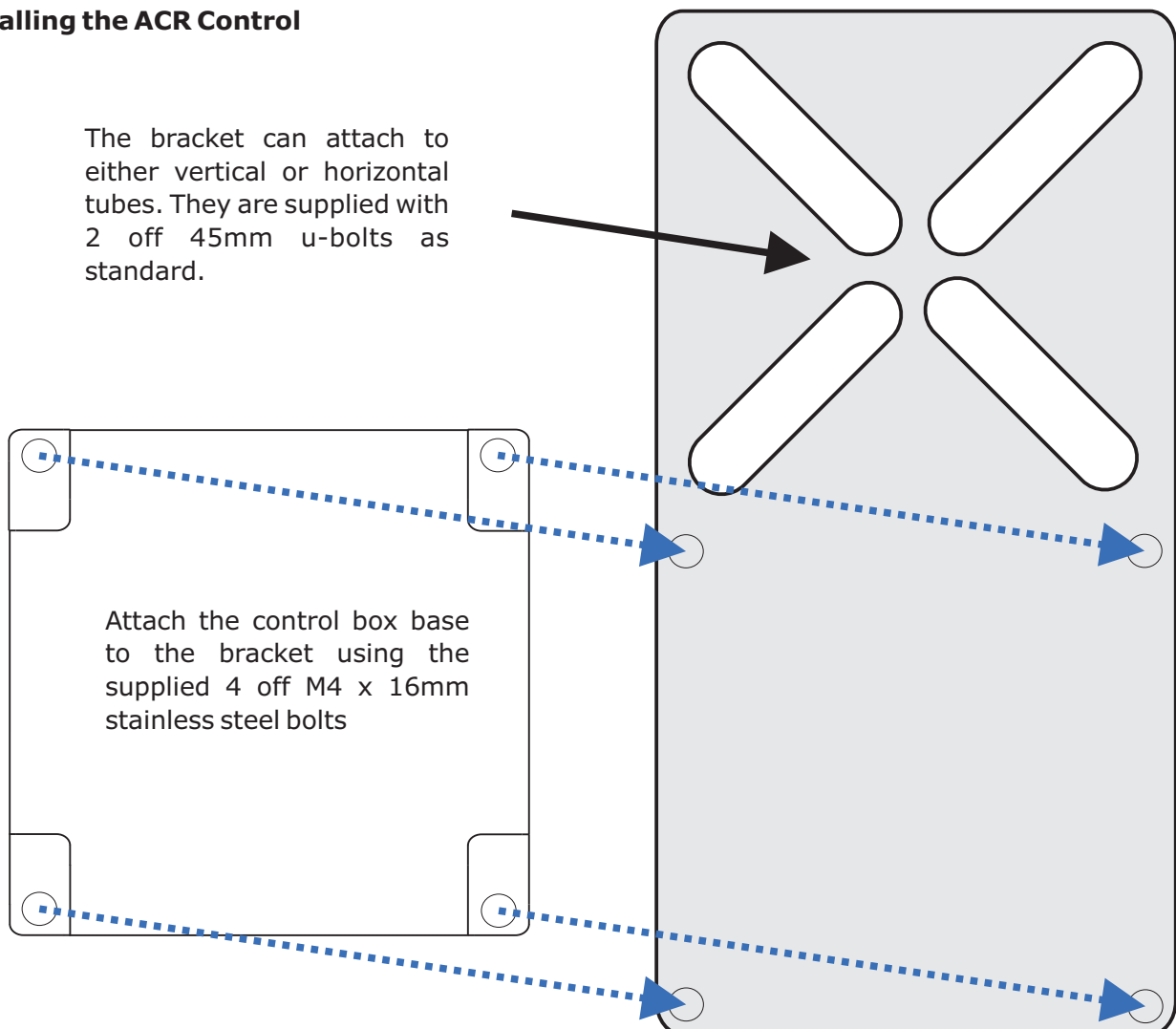

ACR Control Wiring Connections

The ACR control wiring connections are shown in the diagram and corresponding table below.

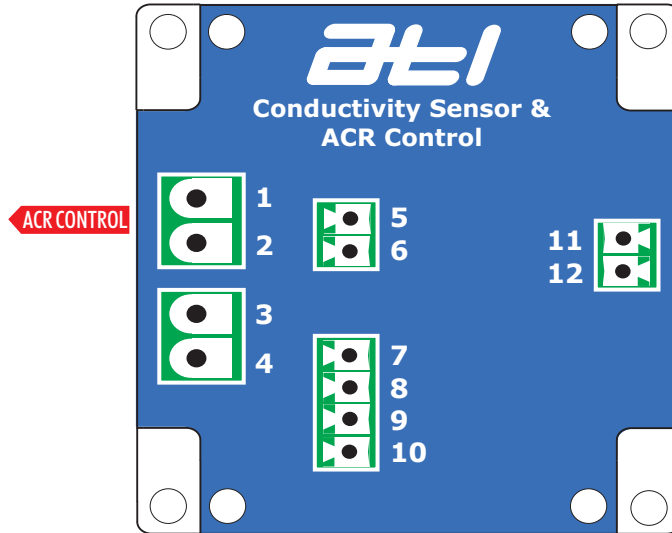

Number	Connects To	Cable Specification
1	Power In +12vDC	Minimum 1.0mm ² 2 core 10A cable
2	Power In -12vDC	Minimum 1.0mm ² 2 core 10A cable
3	Power Out +12vDC	Minimum 1.0mm ² 2 core 10A cable
4	Power Out -12vDC	Minimum 1.0mm ² 2 core 10A cable
5	Auto Start Ram -	Factory Fitted to Auto Start Ram
6	Auto Start Ram +	Factory Fitted to Auto Start Ram
7	Shut Off Valve Solenoid -12vDC	Factory Fitted to Control Valve
8	Shut Off Valve Solenoid +12vDC	Factory Fitted to Control Valve
9	ACR Solenoid -12vDC	Factory Fitted to Control Valve
10	ACR Solenoid +12vDC	Factory Fitted to Control Valve
11	ACR Sensor +	Factory Fitted to ACR Sensor
12	ACR Sensor -	Factory Fitted to ACR Sensor

The ACR control comes with a 4 port gland. If an auto start ACR ram is being used, the power out connection should not be used. Instead the connections should be made within the trunking. The 4 port gland can take a maximum cable OD of 6.5mm.

IMPORTANT - DO NOT INSTALL TWO CABLES THROUGH 1 CABLE HOLE IN THE 4 PORT GLAND. THIS WILL INVALID THE WARRANTY.



Switch Mode Power Supply Wiring Connections

- Mains Voltage: 100-240volt AC
- Output Voltage: Nominal 13.6volt DC
- Mains Fuse: 5 Amp
- Automatic Over Current Protection
- Maximum Number Of ACR Controls With Interpuls CV20 ACR Valve: 60

NB - Maximum number of ACR controls will depend upon ACR control valve solenoid specifications - if unsure please contact ATL.

- Ensure the loading on each power supply is as even as possible.
- Recommended ACR Solenoid Spec: 12 volt DC Continuous Operation Normally Closed with power rating up to 5 watts.
- Recommend system is powered on all of the time to prevent condensation build up on electronic components.

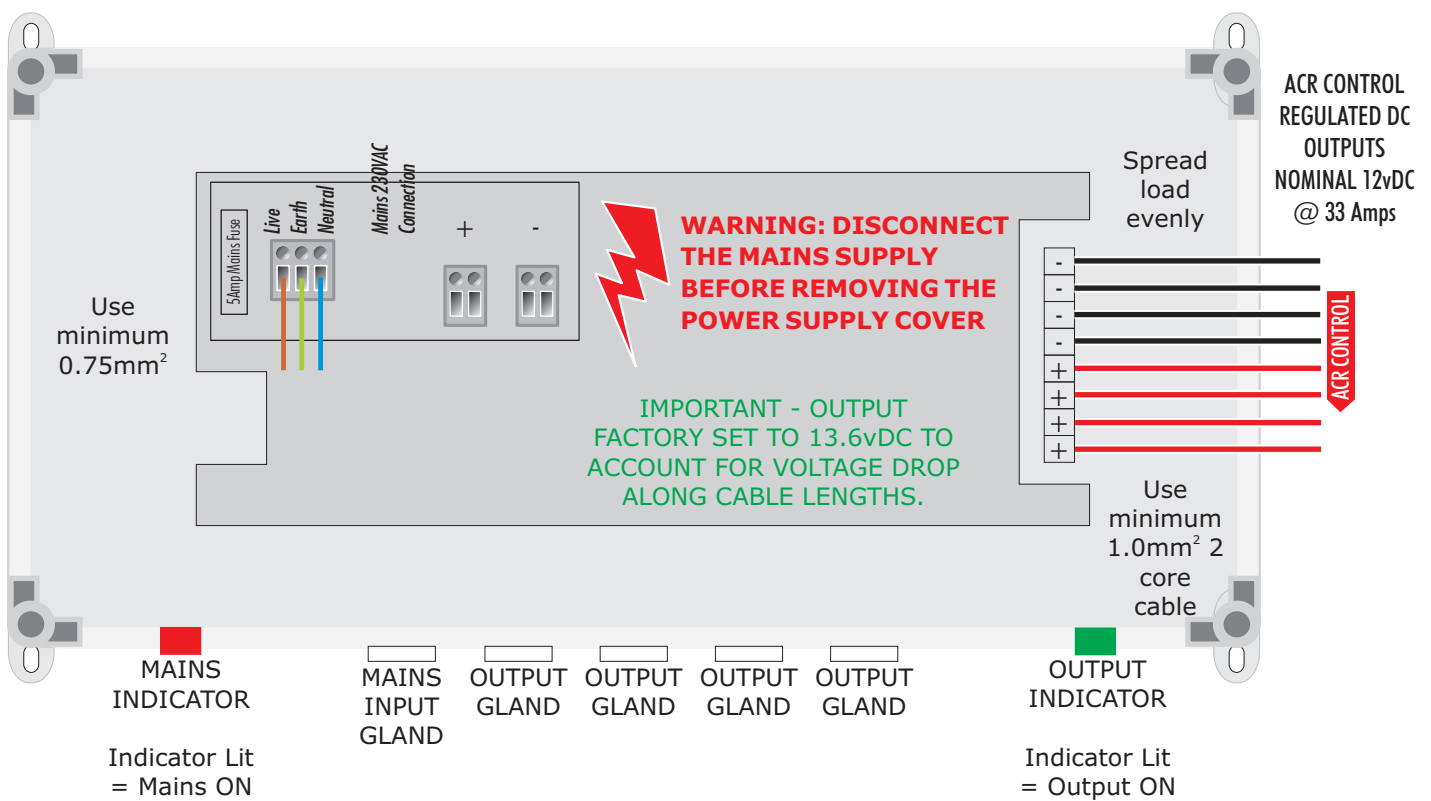

ACR CONTROL

Connect to ACR controls.

Output Specification: Nominal 12vDC @ 33 Amps

IMPORTANT - Use different cable for each block of 10 ACR controls to provide for current requirements of system. This is based upon using CV20 control valve with nominal 3 watts per solenoid coil. If using existing control valve, please check wattage and reduce numbers accordingly.



System Wiring Overview - Standard ACR Ram

NB - The 12vDC power cable is daisy chained between the ACR controls.

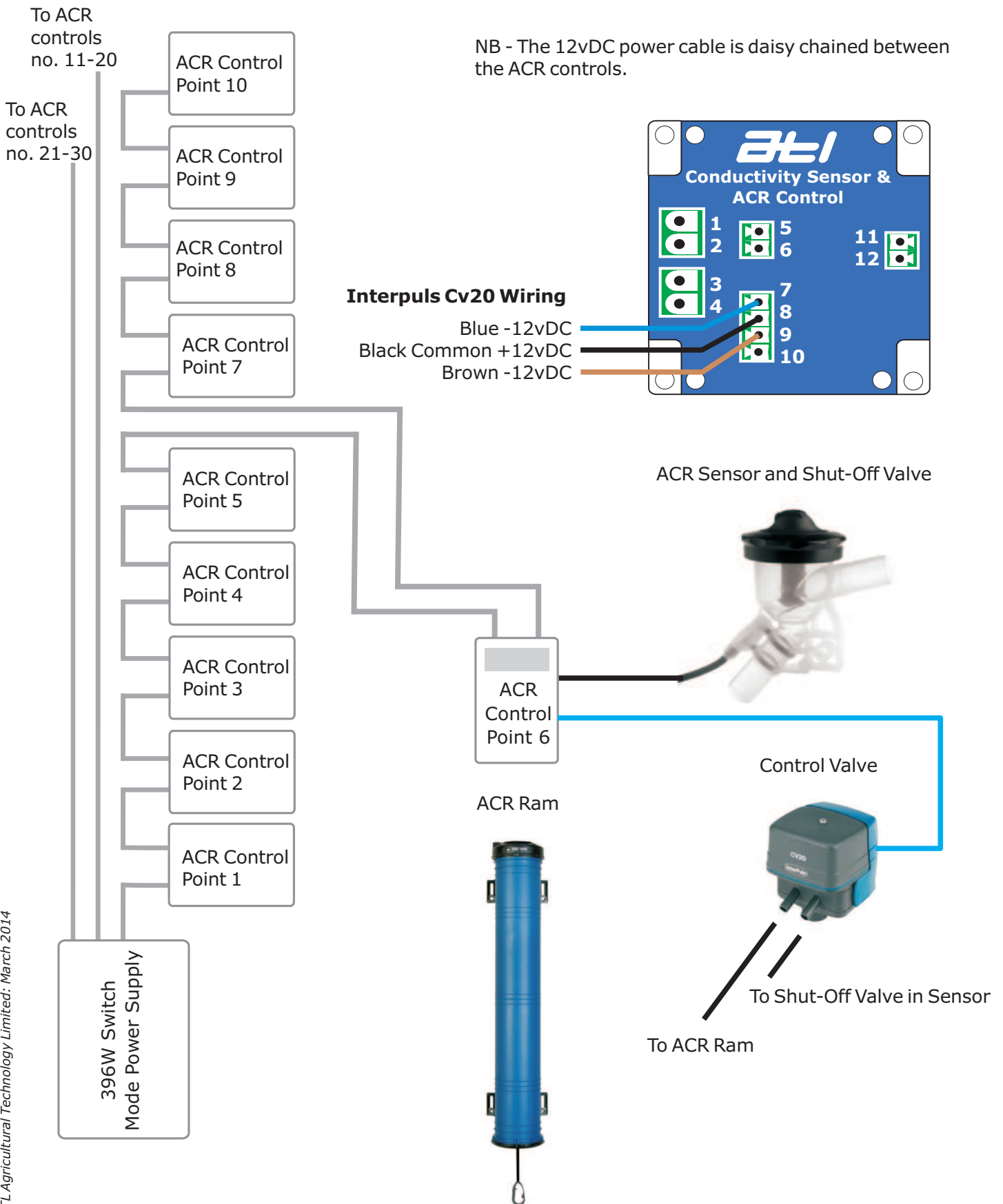



System Wiring Overview - Auto-Start ACR Ram

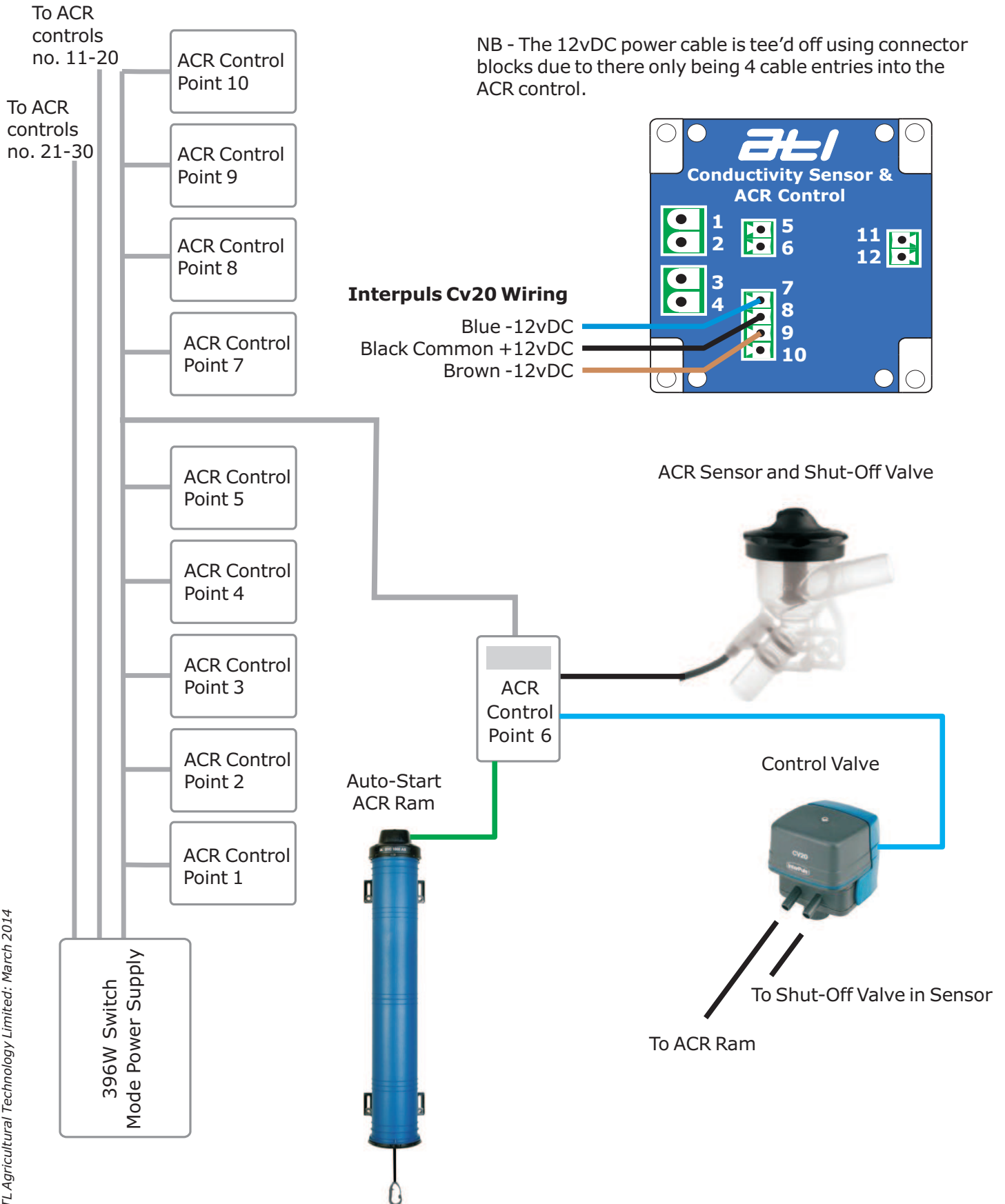



Setting up the ACR Control

Before it can be used, the ACR system must be setup. This is outlined in the following pages:

Accessing the Settings

Press and hold the Conductivity and Milking together first and then press the Manual key, whilst holding the Conductivity and Milking keys (from software version 1.10).



The ACR Function

This setting controls the ACR function. It is a YES / NO setting. YES equals on and NO equals off. The factory default is YES.



Press the Manual key to select YES



Press the Conductivity key to select NO



When the correct setting is selected, press the Milking key to store the data.



If the ACR is set to YES, the ACR hold off delay setting is displayed. If it is set to NO, the conductivity setting is displayed.

The ACR Hold Off Delay Setting

The ACR hold off setting lets the user specify the length of time before the ACR becomes active after the start of milking. The range is from 10 seconds to 240 seconds. The factory default is 120 seconds.

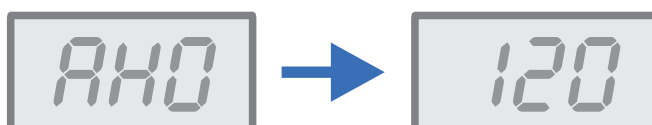



Press the Manual key to increase the time



Hold the Manual key and then the Conductivity key to increase in 10s

Press the Conductivity key to decrease the time



Hold the Conductivity key and then the Manual key to decrease in 10s

When the correct setting is selected, press the Milking key to store the data.



The kick off delay setting is now displayed.

The Kick Off Delay Setting

The kick off delay setting lets the user specify the length of time after the ACR hold off delay has passed, that if an ACR take off occurs, the control will give a kick off alert. The range is from 30 seconds to 999 seconds.

The factory default is 180 seconds.

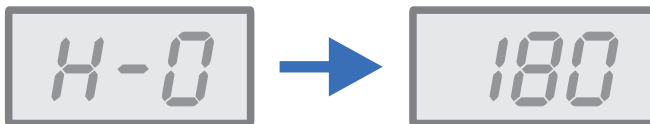

Press the Manual key to increase the time



Hold the Manual key and then the Conductivity key to increase in 10s

Press the Conductivity key to decrease the time



Hold the Conductivity key and then the Manual key to decrease in 10s

When the correct setting is selected, press the Milking key to store the data.



The ACR pull off resistance setting is now displayed.

The ACR Pull Off Resistance Setting

The ACR pull off resistance setting lets the user specify the maximum resistance that the milk is allowed to be before the ACR pull off timer is activated. If the resistance goes above the value and then falls back below, the ACR pull off timer is reset. The range is from 25 ohms to 999 ohms. The factory default is 500 ohms.

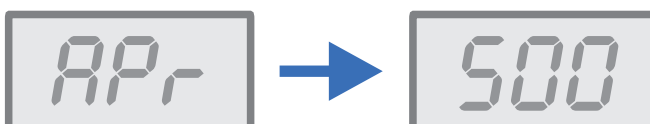



Press the Manual key to increase the time



Hold the Manual key and then the Conductivity key to increase in 10s

Press the Conductivity key to decrease the time



Hold the Conductivity key and then the Manual key to decrease in 10s

When the correct setting is selected, press the Milking key to store the data.



The ACR pull off timer setting is now displayed.

The ACR Pull Off Timer Setting

The ACR pull off timer setting lets the user specify the length of time the resistance must be above the ACR pull off resistance setting before the ACR is activated. The range is from 1 second to 30 seconds.

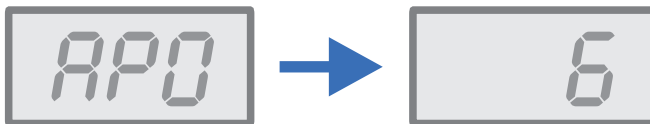

The factory default is 6 seconds.

Press the Manual key to increase the time



Hold the Manual key and then the Conductivity key to increase in 10s

Press the Conductivity key to decrease the time



Hold the Conductivity key and then the Manual key to decrease in 10s

When the correct setting is selected, press the Milking key to store the data.



The conductivity function is now displayed.

The Conductivity Function

The conductivity function allows the display of the conductivity measurement of the milk. It is a YES / NO setting. YES equals on and NO equals off. The factory default is YES.





Press the Manual key to select YES



Press the Conductivity key to select NO



When the correct setting is selected, press the Milking key to store the data.



If the conductivity is set to YES, the conductivity warning level setting is displayed. If it is set to NO, the vacuum delay setting is displayed.

The Conductivity Warning Level Setting

The conductivity warning level setting is the conductivity level whereby the conductivity warning scale LEDs will flash. The range is from 2 millisiemens to 20 millisiemens. The factory default is 5.5 millisiemens.

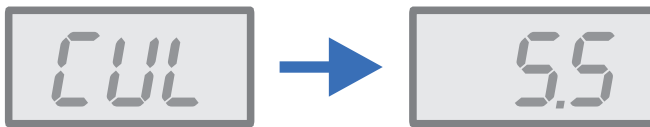

Press the Manual key to increase the time



Hold the Manual key and then the Conductivity key to increase in 10s

Press the Conductivity key to decrease the time



Hold the Conductivity key and then the Manual key to decrease in 10s

When the correct setting is selected, press the Milking key to store the data.



The conductivity pull off level setting is now displayed.

The Conductivity Pull Off Level Setting

The conductivity pull off level setting allows the user to set the conductivity level at which the ACR activates and the cluster is removed from the animal. The range is from 2 millisiemens to 20 millisiemens. The factory default is 6 millisiemens.

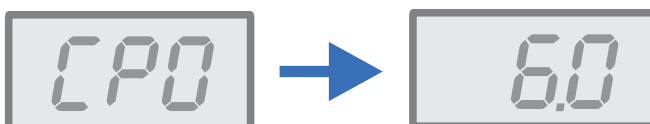



Press the Manual key to increase the time



Hold the Manual key and then the Conductivity key to increase in 10s

Press the Conductivity key to decrease the time



Hold the Conductivity key and then the Manual key to decrease in 10s

When the correct setting is selected, press the Milking key to store the data.



The vacuum delay setting is now displayed.

The Vacuum Delay Setting

The vacuum delay setting allows the user to set a delay between the operation of the shut-off valve closing to shut off the vacuum and the ACR ram operating. It should be set to a value that ensures that as the shut-off valve operates at the end of milking, the vacuum delays to a point where the cluster is just about to fall before the ACR ram operates. The range is from 1 second to 10 seconds. The factory default is 3 seconds.

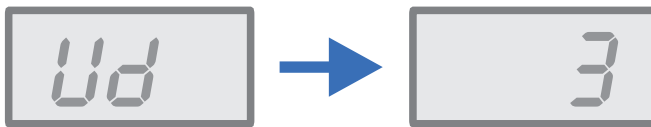

Press the Manual key to increase the time



Press the Conductivity key to decrease the time



When the correct setting is selected, press the Milking key to store the data.



The purge setting is now displayed.

The Purge Setting

The purge setting is a YES / NO setting. When the ACR ram operates, setting the purge to YES makes the shut-off valve momentarily open to purge any milk residues into the milk line. The factory default is YES.





Press the Manual key to select YES



Press the Conductivity key to select NO



When the correct setting is selected, press the Milking key to store the data.



The purge hold off setting is now displayed.

The Purge Hold Off Setting

This setting is only displayed if the purge setting is ON. It allows a delay to be set between the ACR operating and the purge activating. It is for installations with flushing systems. The range is from 1 seconds to 60 seconds. The factory default is 1 second.

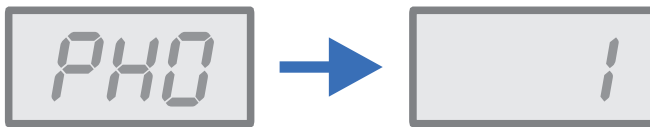

Press the Manual key to increase the time



Hold the Manual key and then the Conductivity key to increase in 10s

Press the Conductivity key to decrease the time



Hold the Conductivity key and then the Manual key to decrease in 10s

When the correct setting is selected, press the Milking key to store the data.



The ACR idle time setting is now displayed.

The ACR Idle Time Setting

The ACR idle time setting is the time in minutes when the ACR control is not in use before it will idle itself. The range is from 5 minutes to 360 minutes. The factory default is 15 minutes.

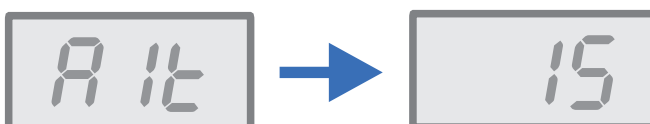



Press the Manual key to increase the time



Hold the Manual key and then the Conductivity key to increase in 10s

Press the Conductivity key to decrease the time



Hold the Conductivity key and then the Manual key to decrease in 10s

When the correct setting is selected, press the Milking key to store the data.



The ACR wash time setting is now displayed.

The ACR Wash Time Setting

The ACR wash time setting is the time in minutes that the wash cycle operates for. The range is from 10 minutes to 720 minutes. The factory default is 30 minutes.

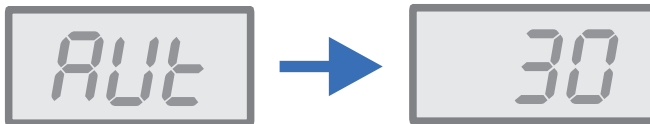

Press the Manual key to increase the time



Hold the Manual key and then the Conductivity key to increase in 10s

Press the Conductivity key to decrease the time



Hold the Conductivity key and then the Manual key to decrease in 10s

When the correct setting is selected, press the Milking key to store the data.



The start input is edge setting is now displayed.

The Start Input Is Edge Setting

The start input is edge setting is a YES / NO setting. This setting selects between the start input being a pulse (low to high - YES) or an edge trigger (NO). The factory default is NO .





Press the Manual key to select YES



Press the Conductivity key to select NO



When the correct setting is selected, press the Milking key to store the data.



The settings are now saved and the setup routine will exit.



Using the ACR Control

The ACR control has four milking modes - these are:

1. Automatic ACR removal and conductivity enabled;
2. Automatic ACR removal and conductivity disabled;
3. Manual ACR removal and conductivity enabled;
4. Manual ACR removal and conductivity disabled.

Automatic ACR removal allows the user to start the milking process and the ACR control completes it (i.e. the ACR ram removes the clusters from the cow and the milking is finished without user intervention).

Manual ACR removal allows the user to control the whole milking process from cluster attachment to removal.

The Milking Procedure

Press the milking key to start milking in automatic mode;



- The 3 digit LED display will show the highest conductivity measurement in millisiemens;
- The LEDs on each key will be green;
- The milking will continue until the ACR removes the cluster automatically EXCEPT if the conductivity of the milk exceeds the conductivity pull off level whereby the cluster will be removed from the animal;
- If the animal is a slow milker or the cluster is removed early, press the manual key (indicated by the manual key LED changing to red). The ACR control will then continue in manual mode until the user manually finishes the milking.



Conductivity Warning Level Indicators and Pull Off

- The conductivity level is shown in two ways:
 1. The highest conductivity level in millisiemens recorded during the animals milking is shown on the 3 digit LED display;
 2. The conductivity level warning scale LEDs give a visual indication of the conductivity of the milk of the animal. If the conductivity level is less than or equal to the conductivity warning level, 3 combinations of LEDs display dependent upon the conductivity level. These are:
 - 2.1 - 1 green LED - conductivity level less than or equal to 1/3 of conductivity warning level;
 - 2.2 - 2 green LEDs - conductivity level less than or equal to 2/3 of conductivity warning level;
 - 2.3 - 2 green LEDs and 1 yellow LED - conductivity level between 2/3 of conductivity warning level and conductivity warning level;
- If the conductivity level is above the conductivity warning level but below the conductivity pull off level, 2 green LEDs and 2 yellow LEDs flash on the conductivity level warning scale LEDs. Further investigation of the animal is required to ascertain whether there is mastitis or another infection.
- If the conductivity level is above the conductivity pull off level, 2 green LEDs, 2 yellow LEDs and 1 red LED flash and the ACR ram removes the cluster from the animal. Further investigation of the animal is required to ascertain whether there is mastitis or another infection.



- If you are milking a mastitic animal, the conductivity warning level indicators can be turned off by pressing the conductivity key. The conductivity key LED will change to red to indicate this.



- If the user would like the conductivity warning level indicator, but not the cluster removed from the animal, set the conductivity pull off level to the maximum setting of 20.0 millisiemens.

Information about Milk Conductivity Measurement

The electrical conductivity of milk is an indication that there might be an infection within the animal (i.e. mastitis). Scientific research suggests that a healthy cow will have a conductivity measurement in the range of 4.0 to 5.5 millisiemens at 25°C. Therefore, an infection can be assumed at values above 5.5 millisiemens. However, this should be backed up by further testing such as the California Milk Test (CMT) to determine whether there is an infection that needs addressing.

It should be noted that the conductivity measurement provided on the ACR control is a guide and should be treated as such.

NB - The conductivity warning level and pull off level are user settable and therefore can be altered to suit individual farm requirements.

The Washing Procedure

- If the clusters are raised, press the manual key on all milking points to lower them, and then place them into the jettets.
- To put the ACR control into wash mode, press the conductivity key, hold it, then press the manual key and hold both until all 3 U's are displayed*. Carry this out on all milking points.



- The 3 digit LED display will show the following and the key LEDs will show the following colours:
- The ACR control will remain in wash mode for the user set ACR wash time period;
- At any point, the user can press and hold the milking key until the 3 U's disappear to remove the ACR control(s) from wash mode*;
- At the end of wash mode, the manual key LED will remain green as the cluster remains in the jetter and therefore the ACR is lowered;
- We recommend that the parlour is cleaned by the circulation of milk stone remover at prevention strength on a weekly basis.

*This is from software version 1.10.

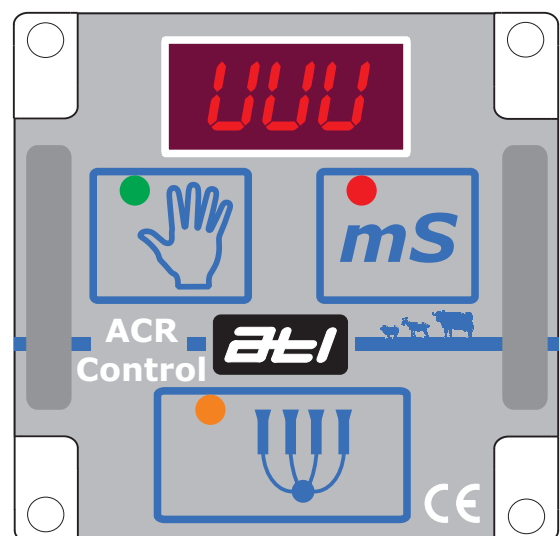



Monthly Routine Maintenance

- Visually inspect the ACR control boxes for damage. Any damage will admit water causing the premature failure of the electronics and should be fixed as soon as possible;
 - Inspect the vacuum lines from the control valve for contamination. Any contamination could indicate the ACR sensor diaphragm has failed;
 - Check the ACR sensor is clean and there is no milk stone build up on the steel rings in the ACR sensor.
-

Six Monthly Routine Maintenance

- In addition to the above monthly checks, check the ACR ram and make sure it operates smoothly.
-

Yearly Routine Maintenance

- In addition to the above monthly and six monthly checks, we recommend replacement of the ACR sensor diaphragm.
 - Thoroughly inspect the control valve, making sure it is clean and operates correctly. Service as required.
-

Parlour Wash Down

- The ACR control enclosure is IP65 rated. However, no indirect or direct pressure washing should be used to wash the ACR control unit, as this will cause the seals to fail and water to ingress and damage the electronic components. Please note that water damage is not covered under warranty.



Additional Items Required to Install ACR System

- 8mm ID PVC signal pipe (10mm OD nipple) to connect from control valve to ACR sensor / shut-off valve and from control valve to ACR ram. Length required installation dependent.
- 19mm milk tube for connection to the ACR sensor. The ACR sensor has 21mm OD inlet and outlets.
- Fixings to fix the ACR sensor to the parlour frame.
- Milk line inlets suitable for 19mm milk tube, if not already available.
- Conduit, mounting and cable for wiring to bringing power to the ACR controls.
- If using an existing ACR ram and solenoid, the solenoid must be 12vDC, otherwise an automotive relay will be required (P/N 16-1048).